

3.2

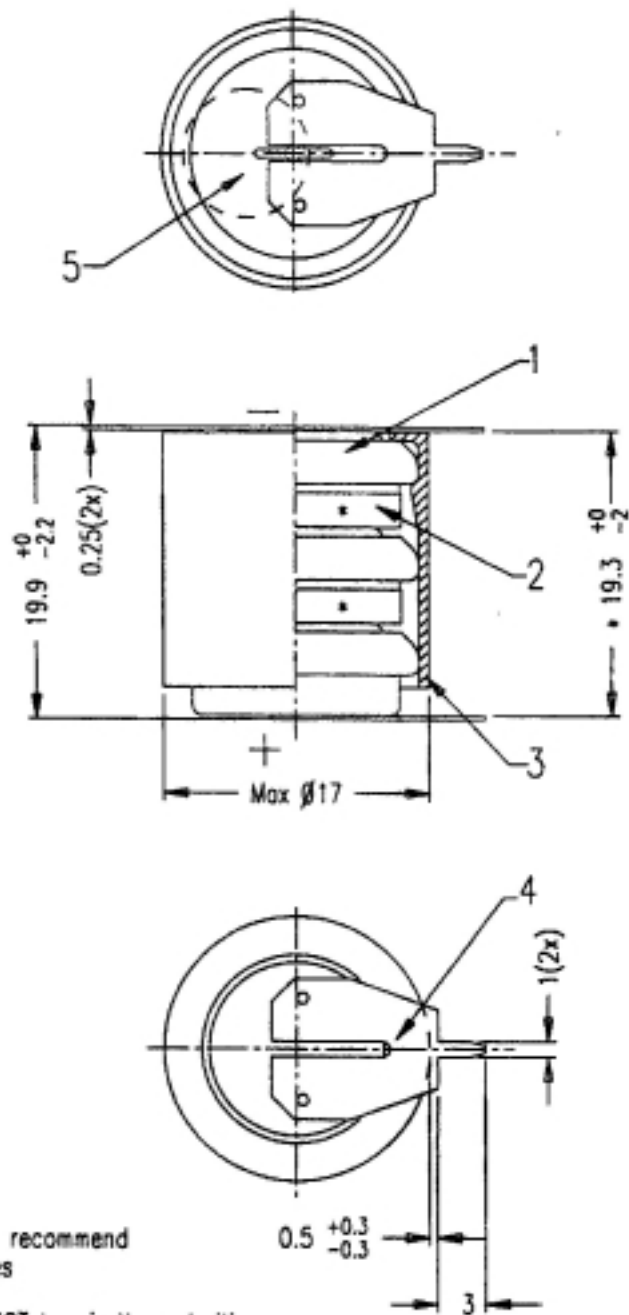

- Note:
- 1) No welding onto the groove
 - 2) For typical PCB application we recommend to use VARTA-Mempac batteries
 - 3) For reference only
 - 4) Special care to be taken ie: NOT to mix the polarities

Approximate weight of battery : 12.0g

No.	Alterations:	Date:	Name:	Dimensions in mm	Material:
				Tolerance: DIN 7168 Medium	Refer to part list no: 070972
				Projection:	Description:
				Scale: 2 : 1	3/V80H battery with snap-on plastic casing & solder tags
				Date: Name:	
				Prepared: 1997-11-10 A.P. ANG	
				Approved: 1998-	

RIGHTS RESERVED TO MAKE TECHNICAL CHANGES, AS A RESULT OF FURTHER DEVELOPMENT, WITHOUT NOTICE. THIS DRAWING IS THE PROPERTY OF VARTA BATTERIES PTE LTD AND MUST NOT BE COPIED OR DISCLOSED TO A THIRD PARTY WITHOUT THE WRITTEN CONSENT OF VARTA BATTERIES PTE LTD.

VARTA
THE BATTERY EXPERTS

Dwg. No: 070972 4/00
VKB Order No: 55608 603 098

Qty No